



The miracles of science™

Technical Data Sheet

Language: English

Applicable for: All over Europe

Effective Date: 09.05.2006



CPD 89/106

Tyvek® 2510B

Type of carrier: laminate of HD-PE & PP with open mesh

DuPont de Nemours (Luxembourg) s.à r.l.
L-2984 Luxembourg

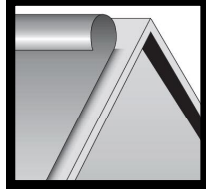
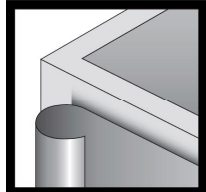
	<p><u>Application:</u></p> <p>Flexible sheets for water proofing – Part 1: Underlays for discontinuous roofing</p> <p>EN 13859-1 (Feb 2005)</p>
	<p><u>Application:</u></p> <p>Flexible sheets for water proofing – Part 2: Underlays for walls</p> <p>EN 13859-2 (Dez 2004)</p>

PROPERTY	METHOD	UNITS	NOMINAL (Mean value)	TOLERANCE	
				Minimum	Maximum
Length (expressed in m)	EN 1848-2	%	Customer related	0	-
Width (expressed in mm)	EN 1848-2	%	Customer related	-0,5	+1,5
Straightness	EN 1848-2	mm	-	-	30
Mass per unit area	EN 1849-2	gr/m ²	408	385	430
Reaction to fire	EN11925-2	Class	E		
Water tightness	EN 1928 (method A)	Class	W1	-	-
Water vapour transmission	EN ISO 12572	m	0,02	0,01	0,04
Maximum tensile force (MD)	EN 12311-1	N/50mm	340	290	390
Elongation at max. tensile force (MD)	EN 12311-1	%	13	10	16
Maximum tensile force (XD)	EN 12311-1	N/50mm	295	250	340
Elongation at max. tensile force (XD)	EN 12311-1	%	20	15	25
Resistance to tearing MD (nail shank)	EN 12310-1	N	165	125	215
Resistance to tearing XD (nail shank)	EN 12310-1	N	170	130	210
Resistance to penetration of air	EN12114	m ³ /(m ² hr.50Pa)	-	-	0,1
Dimensionnel stability (MD & XD)	EN 1107-2	%	-	-	1
Flexibility at low temperature	EN 1109	°C	-	-	-40
Artificial ageing by UV and heat:	EN 1297 & EN 1296	Residual value	aged/new material		
Maximum tensile force in MD	EN 12311-1	%	90	-	-
MD elongation at max tensile force	EN 12311-1	%	85	-	-
Maximum tensile force in XD	EN 12311-1	%	90	-	-
XD elongation at max tensile force	EN 12311-1	%	85	-	-
Water tightness	EN1928 (A)	Class	W1	-	-
ADDITIONAL PROPERTIES					
Temperature resistance	-	°C	-	-40	+100
UV resistance	-	months	-	-	4
Water column	EN 20811	m	-	2	-
Windtight	-	-	yes	-	-

Some test methods are modified according to the EN 13859-1&2 and/or according to the DuPont DIN EN ISO 9001 (2000) certified quality system (for details please contact your regional DuPont representative). This information corresponds to our current knowledge on the subject. It is offered solely to provide possible suggestions for your own experimentation. It is not intended, however, to substitute for any testing you may need to conduct to determine for yourself the suitability of our products for your particular purposes. This information may be subject to revision as new knowledge and experience becomes available. Since we cannot anticipate all variations in actual end-use conditions, DuPont makes no warranties and assumes no liabilities in connection with any use of this information. Nothing in this publication is to be considered as a license to operate under or a recommendation to infringe any patent right. Product safety information is available on request. This data sheet is a printed document and is valid without signature

The DuPont Oval, DuPont™, The miracles of sciences & Tyvek are registered trademarks or trademarks of DuPont or its affiliates

Address:
Rue Général Patton, Contern
L-2984 Luxembourg

Tyvek® Marketing
Tyvek® Customer Service
Tyvek® Manufacturing

Fax (00352) 3666 5021
Fax (00352) 3666 5018
Fax (00352) 3666 5020